



TJM TORQ WINCH RANGE UPDATE

9,500LB & 12,000LB CABLE & SYNTHETIC ROPE

Product Information

Venture further afield and explore Australia's most exciting 4WD destinations with a TJM Torq Winch.

Whether you're travelling on your own or in a group, a winch is a powerful recovery tool that makes extracting vehicles simple and safe. Plus, because local tracks and far-off places both have the potential to get 4x4s stuck, a winch is useful to have on either a weekend away or on a solo Outback adventure.

- More compact control box with two control plug mounting options
- Low profile mount bracket allows more fitment options
- Integrated IP67 wireless transceiver into control box (no longer an external plug in)
- Wireless hand piece now can be turned on and off, meaning no accidental winch operation

New re-designed control box

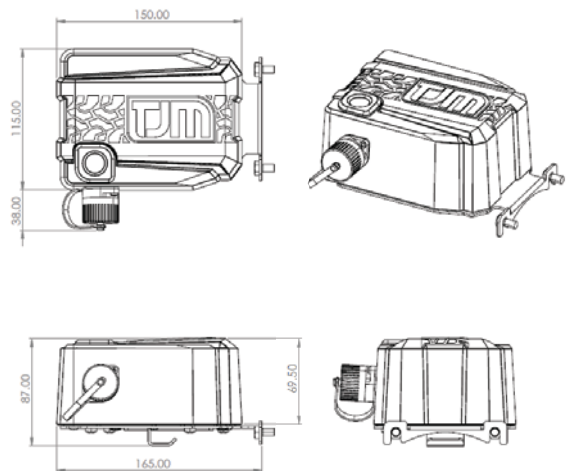

Features

- IP67 winch body - sealed motor and gearbox to prevent water and dust ingress
- IP67 compact control box
- 2 position hand controller plug mount
- Fast line speed
- Contactor control pack
- High output series wound motor
- Planetary gear system
- Automatic load holding brake
- Wireless remote included (Integrated in control box)
- Wireless remote features On/Off operation
- FRP sheath protecting all cables
- Anti-corrosive aluminium tie bars
- 90° clutch handle
- 4 position clocking on motor
- 10 position clocking on gearbox
- Free spooling
- Power in & power out
- Low electric current draw
- CE certified
- Manual isolation switch included
- Optional increased length electrical cable lead kit also available

12,000lb specifications



PART NUMBER. 947TQBK12DAA



PART NUMBER. 947TJMTQ12DAA

	Line load LBS/KGS	Line speed		Motor AMPS
		MPM	FPM	
Rated line Pull.....	12000lbs (5445kg), single line			
Motor (series wound).....	12 Volt, input power 4.9hp (3.6kw)			
Gear train	3 stage planetary	0 / 0	7.8	25.6
Gear ratio	210:1	2000 / 907	4	13.1
Drum.....	Hardened drum	4000 / 1810	2.6	8.5
Fairlead (synthetic rope)	Aluminium hawse fairlead	6000 / 2720	2.0	6.6
Winch dimensions.....	528 x 161 x 200mm (L x W x H)	8000 / 3630	1.7	5.6
Mounting bolt pattern	254 x 114.3mm	9500 / 4310	1.65	5.4
Rope supplied	9.5mmø synthetic rope 28m			300.0

9,500lb specifications



PART NUMBER. 947TQBK95DAA



PART NUMBER. 947TJMTQ95DAA



PART NUMBER. 947TJMTQ95SAA

	Line load LBS/KGS	Line speed		Motor AMPS
		MPM	FPM	
Rated line Pull.....	9500lbs (4310kg), single line			
Motor (series wound).....	12 Volt, input power 4.9hp (3.6kw)			
Gear train	3 stage planetary	0 / 0	7.4	24.3
Gear ratio	150:1	2000 / 907	4	13.1
Drum.....	Hardened drum	4000 / 1810	2.7	8.9
Fairlead (synthetic rope)	Aluminium hawse fairlead or	6000 / 2720	2.3	7.5
Fairlead (steel cable).....	Roller fairlead	8000 / 3630	1.9	6.1
Winch dimensions.....	528 x 161 x 200mm (L x W x H)	10000 / 4540	1.5	4.9
Mounting bolt pattern	254 x 114.3mm	12000 / 5440	1.1	3.6
Rope supplied	9.5mmø synthetic rope 28m or			310.0
Cable supplied	9.5mmø aircraft steel cable 28m			360.0